

# Irrigation Products

# 2025

Offering a complete range of stainless steel and galvanised wire ropes and fittings for irrigation systems.

# Irrigation Products



Designed for the toughest irrigation applications, our products deliver quality, reliability and value.

Arcus Wire Group (AWG) is an industry leading supplier and manufacturer of stainless steel and galvanised wire rope, fittings and accessories. Operating across Australasia for over 60 years, AWG supplies products to the Marine, Industrial and Agricultural sectors.



Both warehouses in NSW and QLD stock a wide range of products including wire rope from 0.8mm to 36mm. Our in-house machinery includes 60t and 300t test beds, and hydraulic swaging tools capable of pressing wire rope up to 42mm.

For more information please give us a call on 1800 ARCUSW (1800 282 879) or visit [www.arcuswire.com](http://www.arcuswire.com) to view our full range our wire ropes and fittings.

If you require irrigation solutions from bore pump cable assemblies, travelling irrigator cable or a fully engineered and tested control cable, AWG has you covered.

## Thimble

SF234U

PRODUCT CODE	SIZE (MM)	B (MM)	L (MM)	T (MM)	
HM-6234-0003	3	12.5	28.5	1	3,500
HM-6234-0004	4	13	33.0	1.2	2,000
HM-6234-0005	5	15.5	36.5	1.2	1,500
HM-6234-0006	6	17	40	1.5	1,000
HM-6234-0008	8	22.5	51	1.5	500
HM-6234-0010	10	26	58.5	2	300

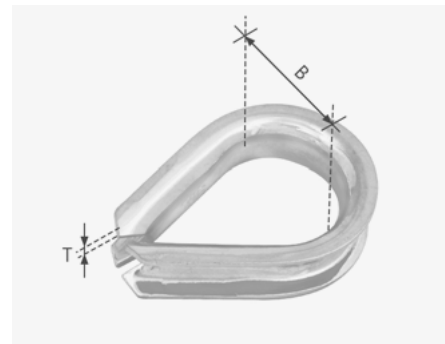

## Wire Rope Grip

S260

PRODUCT CODE	SIZE (MM)	B (MM)	L (MM)	M (MM)	
HM-6260-0003	3	8	21	M3	2,500
HM-6260-0004	4	10	23	M4	1,200
HM-6260-0005	5	12	29	M5	800
HM-6260-0006	6	14	32	M6	500
HM-6260-0008	8	17.5	40	M8	300
HM-6260-0010	10	21	50	M10	200



## Galvanised Bore Pump Cable

G2070 7x19

PRODUCT CODE	SIZE (MM)	REEL SIZE	MBL (KN)	MBL (KGF)	WEIGHT P/M
G079032-1000	3.2mm	1000m	7.1	723	0.039
G079032C	3.2mm	Cut	7.1	723	0.039
G079040-1000	4.0mm	1000m	10.3	1,051	0.061
G079040C	4.0mm	Cut	10.3	1,051	0.061
G079050-1000	5.0mm	1000m	16.0	1,632	0.095
G079050C	5.0mm	Cut	16.0	1,632	0.095
G079060-1000	6.0mm	1000m	23.1	2,356	0.137
G079060C	6.0mm	Cut	23.1	2,356	0.137

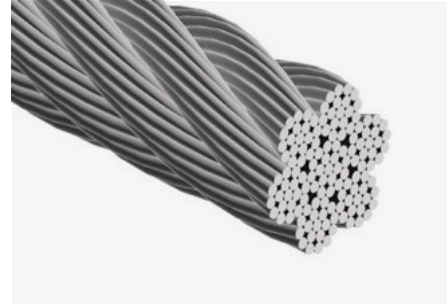

AWG stocks a wide range of sizes in addition to products listed. Please contact our team for more information.

## Stainless Bore Pump Cable

hamma® X G316 7x19

PRODUCT CODE	SIZE (MM)	REEL SIZE	MBL (KN)	MBL (KGF)	WEIGHT P/M
HMX79032-305	3.2mm	305m	6.0	611	0.043
HMX79032C	3.2mm	Cut	6.0	611	0.043
HMX79040-305	4.0mm	305m	9.4	956	0.067
HMX79040C	4.0mm	Cut	9.4	956	0.067
HMX79050-305	5.0mm	305m	14.6	1,490	0.104
HMX79050C	5.0mm	Cut	14.6	1,490	0.104
HMX79060-305	6.0mm	305m	20.6	2,105	0.150
HMX79060C	6.0mm	Cut	20.6	2,105	0.150



AWG stocks a wide range of sizes in addition to products listed. Please contact our team for more information.

## Galvanised Travelling Irrigator Cable

G2070 7x7

PRODUCT CODE	SIZE (MM)	REEL SIZE	MBL (KN)	MBL (KGF)	WEIGHT P/M
G077050-1000	5.0mm	1000m	17.2	1,754	0.096
G077050C	5.0mm	Cut	17.2	1,754	0.096
G077060-1000	6.0mm	1000m	24.7	2,519	0.138
G077060C	6.0mm	Cut	24.7	2,519	0.138
G077070-1000	7.0mm	1000m	33.6	3,427	0.188
G077070C	7.0mm	Cut	33.6	3,427	0.188
G077080-1000	8.0mm	1000m	43.9	4,478	0.246
G077080C	8.0mm	Cut	43.9	4,478	0.246



# Slip Hook (Eye End with Safety Latch)

S325X

PRODUCT CODE	SIZE (INCH)	ØB (MM)	L (MM)	O (MM)		B.L. (KGS)
HM-6325-5516	5/16"	16	108	24	100	2,900



# Twisted Shackle

S380

PRODUCT CODE	SIZE (MM)	ØA (MM)	B (MM)	L (MM)		B.L. (KGS)
HM-6380-0006	6	6	12	36	600	1,600
HM-6380-0008	8	8	16	44	180	2,800



# Twisted Shackle with Collared Pin

S380CP

PRODUCT CODE	SIZE (MM)	ØA (MM)	B (MM)	L (MM)		B.L. (KGS)
HM-6360-8010	10	10	20	51	200	4,600



# D Shackle

S360

PRODUCT CODE	SIZE	ØA (MM)	B (MM)	L (MM)		B.L. (KGS)
HM-6360-0006	6	6	12	24	1,200	1,700
HM-6360-0008	8	8	16	32	500	2,800



## D Shackle with Collared Pin

S360CP

PRODUCT CODE	SIZE (MM)	ØA (MM)	B (MM)	L (MM)		B.L. (KGS)
HM-6360-0410	10	10	20	40	250	4,500
HM-6360-0412	12	12	24	48	150	6,000



## D Shackle Long

S362

PRODUCT CODE	SIZE (MM)	ØA (MM)	B (MM)	L (MM)		B.L. (KGS)
HM-6362-0008	8	8	16	64	300	2,500

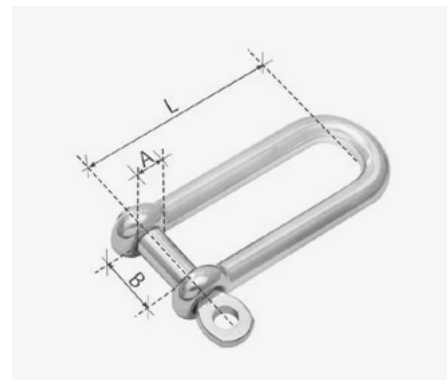

## D Shackle Long with Collared Pin

S362CP

PRODUCT CODE	SIZE (MM)	ØA (MM)	B (MM)	L (MM)		B.L. (KGS)
HM-6362-3010	10	10	20	80	150	3,500
HM-6362-3012	12	12	24	96	80	5,400



## Eye-Eye Turnbuckle

S311EE

PRODUCT CODE	SIZE (MM)	L (MM)	L1 (MM)	M (MM)		B.L. (KGS)
HM-6311-7006	6	154	90	M6	300	1,500
HM-6311-7008	8	210	120	M8	150	2,300
HM-6311-7010	10	257	150	M10	80	3,100

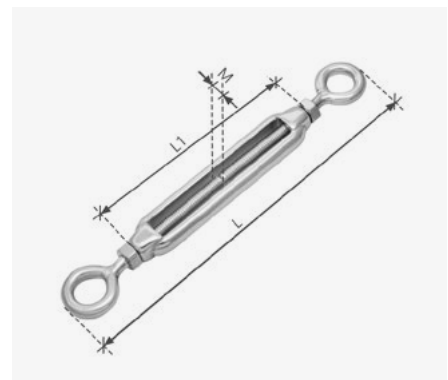

# Medium Link Chain

316 Grade Stainless Steel

Arcus Wire Group's Medium Link Chain is sourced from the largest stainless steel chain manufacturer in Asia to exacting ISO9001(2015) standards.

Available in a range of sizes, the G316 Medium Link Chain is commonly used in the shade sail industry, as well as architectural projects and general marine applications.

As with all products supplied by Arcus Wire Group, Mill certificates are available on request for all G316 Medium Link Chain orders.

Importantly, the G316 Medium Link Chain is not suitable for lifting purposes or anchor winch applications. Please contact the Arcus Wire Group team for information about products suitable for these applications.

PRODUCT CODE	SIZE (MM)	WEIGHT (KG)	F (MM)	H (MM)	J (MM)	GRADE
AWG-CH316-04M*	4.0	0.3	4.0	18.6	8.0	G316
AWG-CH316-05M*	5.0	0.5	5.0	22.0	9.4	G316
AWG-CH316-06M	6.0	0.77	6.0	26.0	11.5	G316
AWG-CH316-08M	8.0	1.3	8.0	32.2	13.5	G316
AWG-CH316-10M	10.0	2.05	10.0	39.0	16.2	G316
AWG-CH316-12M	12.0	2.95	12.0	46.0	20.0	G316
AWG-CH316-16M*	16.0	5.0	16.0	59.6	24.5	G316

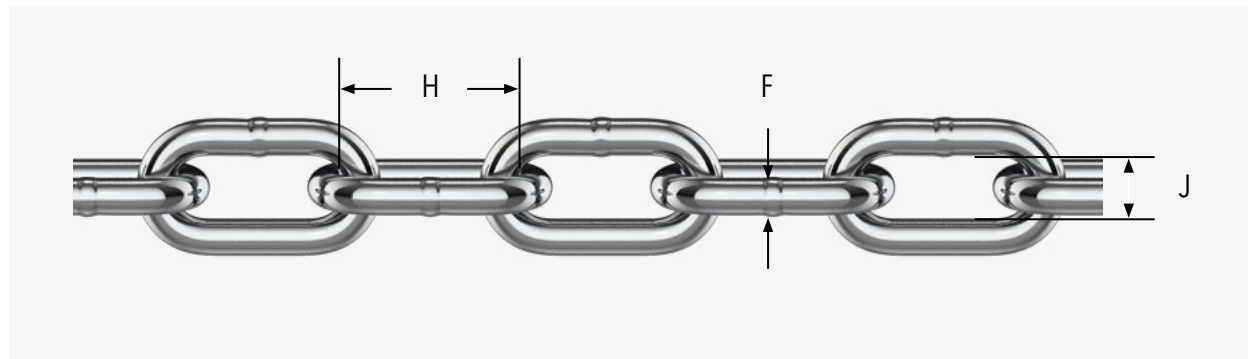

## Nicopress N5606 Battery Tool

N5606

PRODUCT CODE	SUITS (MM)	CRIMP TIME	WEIGHT	CRIMPS PER CHARGE
N5606	N24C, N32C, N40C, N48C, N55C, N64C, N80C and N95C	6 seconds	3.8kgs	250

### SPECIAL NOTE

N5606 Battery Tool suits Nicopress N5606 Dies.  
Includes Tool, Wrist Strap, Two Batteries, Battery Charger and Moulded Carrying case.



## Nicopress N5606 Dies

N5606

PRODUCT CODE	SUITABLE TO USE WITH
NBTD2.4MM	2.4mm, 2.5mm or 3/32"
NBTD3.2MM	3.0mm, 3.2mm, 3.5mm or 1/8"
NBTD4MM	4.0mm or 5/32"
NBTD4.8MM	4.8mm, 5.0mm or 3/16"
NBTD5.5MM	5.5mm, 6.0mm or 7/32"
NBTD6.4MM	7.0mm, 6.4mm or 1/4"
NBTD8MM	7.2mm, 8.0mm, 9/32" or 5/16"
NBTD9.6MM	10.0mm or 3/8"



### SPECIAL NOTE

N5606 can swage all sleeves noted below.

## Nicopress Tin Plated Oval Sleeves

Hand Swage

PRODUCT CODE	TOOL REQUIRED
N08C	N31B
N12C	N17-B4B or N33V
N16C	N5606, N33V or N64CG
N24C	N5606, N33V or N64CG
N32C	N5606, N33V or N64CG
N40C	N5606, N33V or N64CG
N48C	N5606 or N63V
N55C	N5606 or N51F
N64C	N5606 or N3F6
N80C	N5606 or N3G9
N95C	N5606 or N3H5



### SPECIAL NOTE

When swaging correctly Nicopress ferrules reach 100% of the MBL of the wire rope. Above ferrules are also available in plain copper or black oxide upon request. N5606 can swage all sleeves noted above.

## Nicopress Stainless Steel Oval Sleeves

PRODUCT CODE	TOOL REQUIRED
N12SS	N33V
N16SS	N51-B4-887
N24SS	N51C-887
N32SS	N51-G-887 or N63V
N40SS	N51M or N63V
N48SS	N-51-P-850 or N63V
N55SS	N-3-X-950
N64SS	N-3-F2-950



## Nicopress Copper Stop Ferrules

PRODUCT CODE	TOOL REQUIRED
N12ST	N51-B4-887 or N17-B4B
N16ST	N51C or N64CG
N24ST	N51M
N32ST	N51M
N40ST	N51M
N48ST	N51M



**SPECIAL NOTE**

Stop Sleeves typically hold between 30-50% of the MBL of the cable.

## Nicopress Aluminum Stop Ferrules

PRODUCT CODE	TOOL REQUIRED
N32STA	N51-C-887 or N64CG
N40STA	N51M
N48STA	N51M
N64STA	N3F6
N80STA	N3F6



**SPECIAL NOTE**

Stop Sleeves typically hold between 30-50% of the MBL of the cable.

## Nicopress Hand Model Crimping tool

N17-B4B

PRODUCT CODE	SUITABLE FOR USE WITH
N17-B4B	N12C, N12ST or N24SS



## Nicopress 33V-CGB4 Swaging Tool

N33V

PRODUCT CODE	SUITABLE FOR USE WITH
N33V	N16C, N24C or N32SS



## Nicopress 64-CGMP Swaging Tool

N64CG

PRODUCT CODE	SUITABLE FOR USE WITH
N64CG	N16C, N24C, N32C, N40C, N16ST, N32STA, N32SS



## Nicopress 63V-XPM Swaging Tool

N63V

PRODUCT CODE	SUITABLE FOR USE WITH
N63V	N32C, N40C, N48C, N32SS, N40SS, N48SS



## Nicopress 51-F2-850 Swaging Tool

N51F

PRODUCT CODE	SUITABLE FOR USE WITH
N51F	N55C, N64C



## Nicopress 51-MJ Swaging Tool

N51M

PRODUCT CODE	SUITABLE FOR USE WITH
N51M	N40SS, N24ST, N32ST, N40ST, N48ST, N40STA, N48STA



## Nicopress 3-F6-950 Swaging Tool

N3F6

PRODUCT CODE	SUITABLE FOR USE WITH
N3F6	N64C, N64STA, N80STA



## Nicopress 3-G9-950 Swaging Tool

N3G9

PRODUCT CODE	SUITABLE FOR USE WITH
N3G9	N80C



### Go gauge usage

Gauging swaged sleeves is an important inspection process to determine if a sleeve has been pressed enough to ensure a full-strength connection to wire rope. Nicopress go gauges are provided with each tool. It's always recommended, while adjusting a hand tool, to gradually increase the compression of the tool to a point where the Nicopress "go-gauge" easily slides (or "goes") over the pressed sleeve resulting in an optimum swage compression.

#### It's a "go" gauge, not a "go-no-go" gauge

A Nicopress "go" gauge is a gauge designed to easily slide or "go" over a properly swaged section of sleeve to be sure a safe amount of compression has been reached. If the gauge tool doesn't slide easily over the swage, or doesn't go, the swage tool must be adjusted to press deeper to allow the gauge to freely pass or "go" over the swage. In theory, this would be an inspection tool to prevent under-pressing occurring during a swaging process.

Refer to Technical Bulletin-2 for "Go-Gauge" or "Go-No-Go" Gauge details.

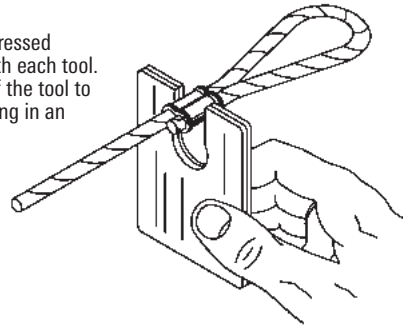

# Fence and Trellis Products

## Strength Aligned

### Where Fastening Power Meets Precision

Achieve excellence in fence and trellis performance with Nicopress' high-quality system for high-tensile fence wire crimping, splicing and taps.

We understand the success of farms, ranches, vineyards and orchards depends on critical applications like:

- Crop protection
- Livestock containment
- Vine trellising and more

Optimised Nicopress® swage compression technology makes these endeavors easier, more economical and more reliable.

### Key Features of the Nicopress® System:

- **Fast, Tidy Fabrication:** We streamline fence and trellis fabrication and maintenance, ensuring speed and precision in every splice.
- **Holding Force:** The fence sleeve's strength matches the Rated Breaking Strength (RBS) of the wire to ensure your splicing is as durable as the wire it secures.
- **Repeatability and Affordability:** Our user-friendly designs and accessible options provide fabricators with the assurance to tackle any fencing project.
- **Expert Guidance:** With end-to-end support, unrivaled field know-how and decades of experience, count on us to enhance your business performance and bottom line.

## Nicopress® Compression Tools

Designed to integrate with Nicopress® fence wire splices, our tools guarantee a reliable connection thanks to:

- **Forged Steel Jaws:** Alloy steel jaws are forged for strength and heat-treated to withstand the toughest conditions.
- **Toggle Action:** An intelligent design helps ensure a complete splice every time, with less time and effort.
- **Easy Inspection:** Precision is paramount and why every Nicopress® tool features a gauge with instructions for adjustment.
- **Adjustable Design:** Adaptability equals efficiency and convenience.



## Hand Swaging Tools

Nicopress® hand swaging tools ensure a proper swage. Hand tools are available with single or multiple pressing grooves.



### Model 64-2345

- Multigroove feature ideal for construction and repair of new and old fence wire
- Length: 20"



### Model 51-G-887

- Single-groove tool ideal for use with high-tensile 12½-gauge fence products
- Length: 18½"



### Model 32-234

- Compact design for crimping Nicopress® FW-2-3 sleeves and FWT 3-4 taps
- Economical option for use with 12½-gauge high-tensile fence wire
- Length: 12"

# Genuine Nicopress® Sleeves and Taps

## Nicopress® Fence Taps

Nicopress® "FWT" fence taps offer a tamperproof, permanent connection for electrified fence wires to charger and ground leads. Easily install jumper lead taps around gates and posts using Nicopress® compression tools.

FENCE TAP PART NUMBER	FENCE WIRE (SLOT "A")	TAP WIRE (SLOT "B")	COMPRESSION TOOL USED*	5606M BATTERY TOOL DIE SELECTION
<b>FWT-3-4</b> for smooth, solid fence wire (electrified)	12½ gauge (.076/.106 dia.)	12 to 14½ gauge (.076/.099 dia.)	64-2345, or 32-234	6-FW34 DIE
<b>FWT-4-5</b> for barbed wire	12½ to 15½ gauge (two .076/ two .099 dia.)	6 to 12 gauge (0.76/.162 dia.)	64-2345	6-FW45 DIE

\* In application, Nicopress® compression tool groove numbers correspond and match Nicopress® fence tap part numbers. Example: Fence tap FWT-3-4 fits into Nicopress® tool groove 3-4.



## Nicopress® Fence Wire Sleeves

Nicopress® Fence Wire Sleeves Nicopress® "FW" fence wire sleeves offer a fast, cost-effective splice for overlapping wires. Made from zinc-plated copper, they excel in lap-splicing and dead-ending woven, barbed and single-strand wires.

Use with Nicopress® compression tools for superior holding strength.



SLEEVE PART NUMBER	FOR WIRE SIZE/TYPE	COMPRESSION TOOL USED*	5606M BATTERY TOOL DIE SELECTION
<b>FW-5-6</b>	7 gauge	3-56	6-FW56 DIE
<b>FW-4-5</b>	9 gauge   12½ barbed 13½ barbed	64-2345	6-FW45 DIE
<b>FW-3-4</b>	10 gauge   11 gauge 14 barbed   15½ barbed	64-2345	6-FW34 DIE
<b>FW-2-3</b>	12½ gauge	64-2345, 51-G-887 or 32-234	6-FW23 DIE
<b>FW-2-3¾"</b>	12½ gauge		6-FW23 DIE
<b>FW-1-2</b>	14½ gauge   15½ gauge	64-2345	6-FW12 DIE

\* In application, Nicopress® compression tool groove numbers correspond and match Nicopress® sleeve part numbers, except for the 51-G-887 tool. Example: Sleeve FW-3-4 fits into Nicopress® tool groove 3-4.

## Nicopress® Butt Type Sleeves



When repair sections of fence must be cut and returned to its original position, Nicopress® butt type sleeves, installed with Nicopress® compression tools, provide a smooth, continuous wire surface. With no wire overlap, this streamlined splice is ideal in trellis applications where automatic equipment may travel the wire.

SLEEVE PART NUMBER	FOR WIRE SIZE/TYPE	COMPRESSION TOOL USED*	COMPRESSION TOOL GROOVE
2-3/081-M	7 gauge	64-2345, or 51-MJ	M or FW-3-4
2-148-J	9 gauge	31-DJ, or 31-CJ	J
2-134-J	10 gauge	31-DJ, or 31-CJ	J
2-120-J	11 gauge	31-DJ, or 31-CJ	J
5-109D-135	12½ gauge	31-DJ, or 31-CJ	D
5-083-C	14½ gauge	31-DJ, or 31-CJ	C
125-JFW	12½ barbed	31-DJ, or 31-CJ	J
135-JFW	13½ barbed	31-DJ, or 31-CJ	J
140-JFW	14 barbed	31-DJ, or 31-CJ	J

\* In application, Nicopress® compression tool groove numbers correspond and match Nicopress® sleeve part numbers, except for the 51-G-887 tool. Example: Sleeve FW-3-4 fits into Nicopress® tool groove 3-4.

## Tools of the Trade

Lightweight, ergonomic Nicopress® hydraulic swaging and cutting tools are engineered for fast, easy, one-hand operation. Die sets for swaging wire are designed specifically for use with Nicopress® sleeves.



### 5606M 6-Ton In-Line Battery Swaging Tool

- Dies available for all fence wire sizes
- 180° rotating head with forged jaws and protective brush guards
- LED lighting
- Two batteries and one 120VAC charger for continuous use
- 400 crimps approx.
- "Tool only" available

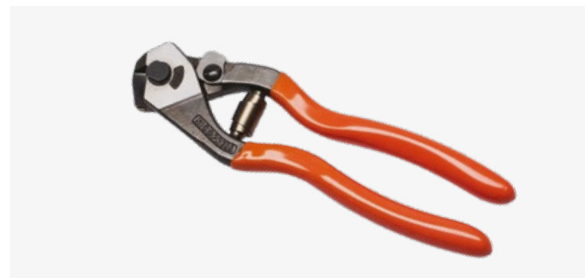

### 1-VC1 Wire and Cable Cutter

- Length 7½"
- Weight 13 oz
- Up to 3/16" cutting capacity

# ABOUT US

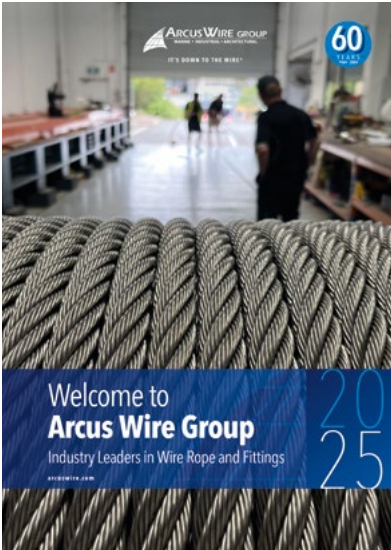

ABOUT ARCUS WIRE GROUP

## ARCUS WIRE GROUP

As a recognised leader in wire rope and fittings for 60 years, Arcus Wire Group brings a wealth of experience, knowledge and expertise to help customers with wire rope projects of any size or complexity.



"We don't just aim to meet your expectations and project requirements; we strive to exceed them while providing remarkable value."

David Sheedy, CEO

## INDUSTRY ACCREDITATION



# BRANDS



# PRODUCTS

## WIRE ROPE AND CHAIN



STAINLESS STEEL WIRE ROPE



GALVANISED WIRE ROPE



MEDIUM LINK CHAIN

## STAINLESS STEEL WIRE MESH



FLEXI-MESH



STANDOFFS

## INDUSTRIAL SOLUTIONS



INDUSTRIAL

## MARINE SOLUTIONS



MARINE

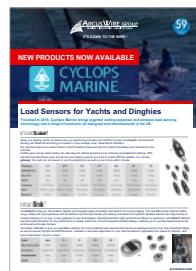

CYCLOPS MARINE

## ARCHITECTURAL SOLUTIONS



ARCHITECTURAL SOLUTIONS

## INDUSTRY SOLUTIONS

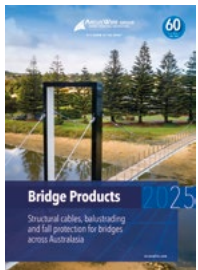

BRIDGES

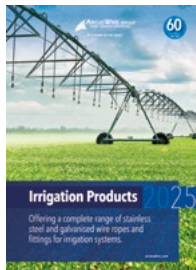

IRRIGATION



DI'VINE LANDSCAPE



STAGING AND RIGGING FOR THEATRES



S307 RATED COLLARED EYE BOLT

# SERVICES

## MANUFACTURING, TESTING AND PRODUCT DESIGN



QUALITY WIRE ROPE CABLE ASSEMBLY AND MANUFACTURING



INDUSTRY LEADING WIRE ROPE TESTING



SPECIALISED PRODUCT DESIGN



FOR MORE INFORMATION  
**1800 ARCUSW**  
1800 272 879  
SALES@ARCUSWIRE.COM

[arcuswire.com](http://arcuswire.com)